

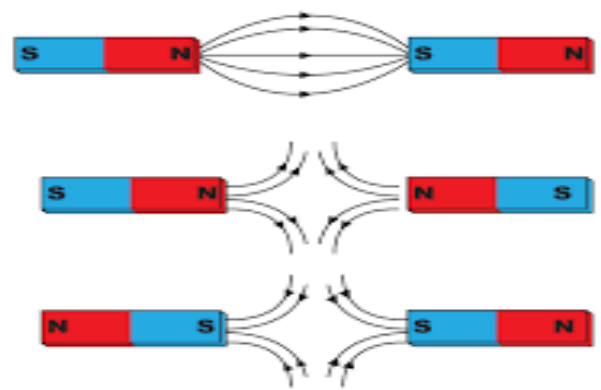

# 1. Magnets

- ✓ 2 like poles will repel
  - ✓ 2 unlike poles will attract
  - ✓ Magnetic materials: Iron, steel, nickel and cobalt
- Magnetic forces are non-contact forces



**Permanent magnet** – produces its **own magnetic field** and can attract or repel another magnet.

**Induced magnet** – becomes a magnet when it is placed in a magnetic field (**temporary** and can **only attract** another material). Magnetism is lost when it leaves the magnetic field.

# 2. Magnetic fields

‘A region around a magnet where a magnetic material will experience a force’

- ✓ Field lines go North to South.
- ✓ Magnetic field is strongest at the poles
- ✓ The strength of the magnetic field decreases the further you get from the magnet

The Earth’s core is magnetic and a tiny magnet (as the needle of a compass) aligns itself to the Earth’s magnetic field so we can plot our direction against the North.

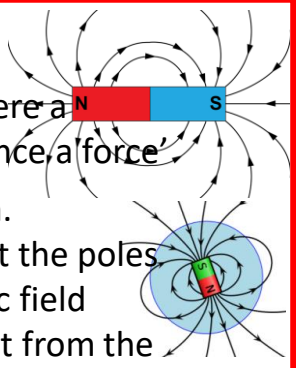

## Plotting a magnetic field

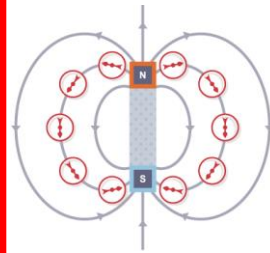

Plotting compasses can be used to show the magnetic field. Place them around the bar magnet. Mark the direction of the arrow at each point. Join the arrows to show the shape of the magnetic field.

When a current flows through a wire, a circular magnetic field is produced around the wire. It is stronger closer to the wire.

**Right hand grip** rule shows the direction of the magnetic field: Thumb = current. Grip = field direction



# 3. Solenoids

A solenoid is a **coiled wire**. Its magnetic field is **strong** and **uniform** inside the coil

Adding an **iron core** makes the solenoid into an **electromagnet**.

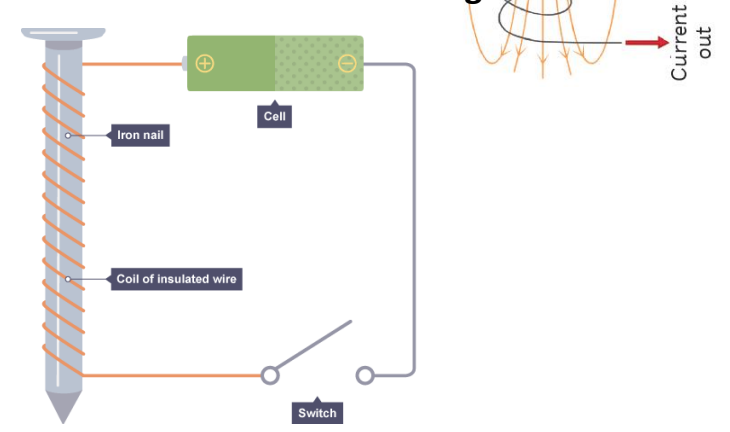

Electromagnets are induced magnets that can be turned on and off. The magnetic field can be increased by:

1. Adding more turns of wire onto the coil
2. Increasing the current
3. Adding an iron core

Electromagnets are used in devices such as electric bells, and door locks that can be controlled remotely.

### 1. Magnets

- ✓ 2 like poles will repel
  - ✓ 2 unlike poles will attract
  - ✓ Magnetic materials: Iron, steel, nickel and cobalt
- Magnetic forces are non-contact forces

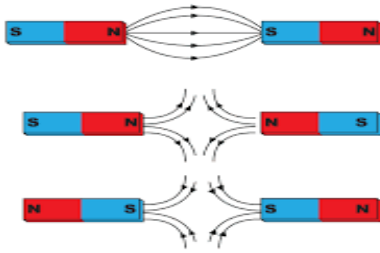

**Permanent magnet** – produces its **own magnetic field** and can attract or repel another magnet.  
**Induced magnet** – becomes a magnet when it is placed in a magnetic field (**temporary** and can **only attract** another material). Magnetism is lost when it leaves the magnetic field.

### 2. Magnetic fields

'A region around a magnet where a magnetic material will experience a force'

- ✓ Field lines go North to South.
- ✓ Magnetic field is strongest at the poles
- ✓ The strength of the magnetic field decreases the further you get from the magnet

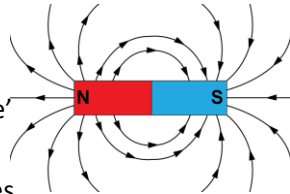

The Earth's core is magnetic and a tiny magnet (as the needle of a compass) aligns itself to the Earth's magnetic field so we can plot our direction against the North.

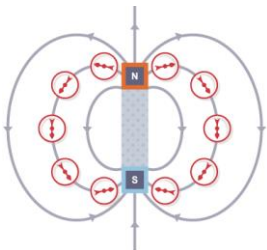
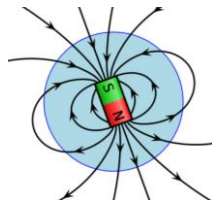

#### Plotting a magnetic field

Plotting compasses can be used to show the magnetic field. Place them around the bar magnet. Mark the direction of the arrow at each point. Join the arrows to show the shape of the magnetic field.

When a current flows through a wire, a circular magnetic field is produced around the wire. It is stronger closer to the wire.  
**Right hand grip** rule shows the direction of the magnetic field: Thumb = current. Grip = field direction

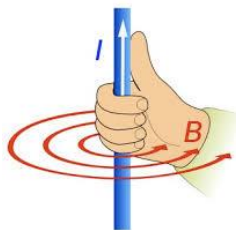

### 3. Solenoids

A solenoid is a **coiled wire**. Its magnetic field is **strong** and **uniform** inside the coil

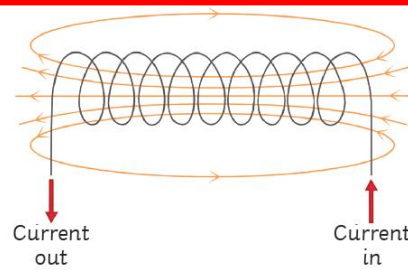

Adding an **iron core** makes the solenoid into an **electromagnet**.

Electromagnets are induced magnets that can be turned on and off. The magnetic field can be increased by:

1. Adding more turns of wire onto the coil
2. Increasing the current
3. Adding an iron core

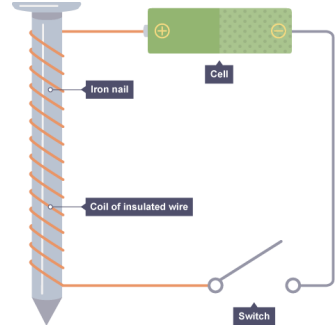

Electromagnets are used in devices such as electric bells, and door locks that can be controlled remotely.

### 4. HIGHER TIER Motor effect

A wire carrying a current creates a magnetic field. This can interact with another magnetic field, causing a force that pushes the wire at right angles. This is the motor effect.

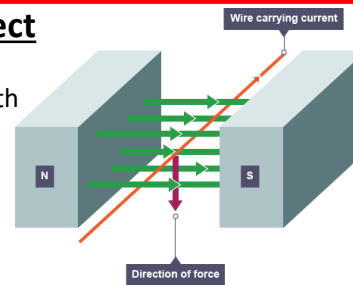

$$F = BIL$$

$$\text{force (N)} = \text{magnetic flux density (T)} \times \text{current (A)} \times \text{length (m)}$$

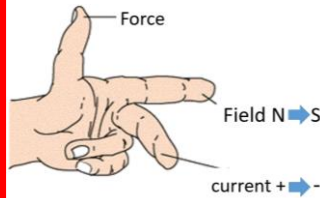

- The force on a length of wire in a magnetic field increases when:
- ✓ the current in the wire increases
  - ✓ the strength of the magnetic field increases

The direction of a motor effect force can be found using Fleming's left hand rule. Thumb = direction of force. 1<sup>st</sup> finger = direction of field. 2<sup>nd</sup> finger = direction of current.

### 5. HIGHER TIER Electric Motors

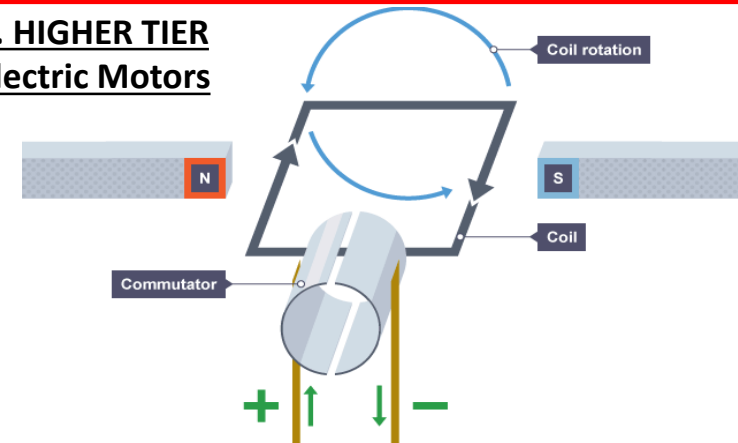

1. Current in the left hand part of the coil causes a downward force, and current in the right hand part of the coil causes an upward force therefore the coil **rotates anti-clockwise**
2. When vertical, the momentum of the motor carries the coil on round a little while a split ring commutator changes the current direction every half turn
3. Once the conducting brushes reconnect with the commutator after a half turn, current flows in the opposite direction through the wire in the coil and each side of the coil is now near the opposite magnetic pole
4. This means that the motor effect forces continue to cause anti-clockwise rotation of the coil.

### 6. HIGHER TIER Transformers

A transformer is a device that can change the potential difference of an alternating current:

- step-up increases voltage (fewer primary than secondary coils)
- step-down reduces voltage (more primary than secondary coils)

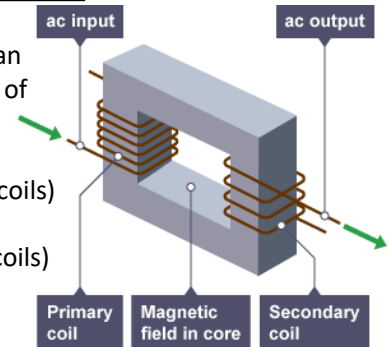

1. The transformer has an iron core which is easily magnetized
2. An alternating current is provided to the primary coil
3. This induces a changing magnetic field in the iron core
4. This induces an alternating current in the secondary coil

### 7. Loudspeakers and headphones

Alternating current supplied to the loudspeaker creates sound waves in the following way:

1. a current in the coil creates an electromagnetic field which interacts with the permanent magnet generating a force; pushing the cone outwards
2. the current is made to flow in the opposite direction and the direction of the electromagnetic field reverses and the force on the cone now pulls it back in

Repeatedly alternating the current direction makes the cone vibrate in and out and these cone vibrations cause pressure variations in the air, which are sound waves.

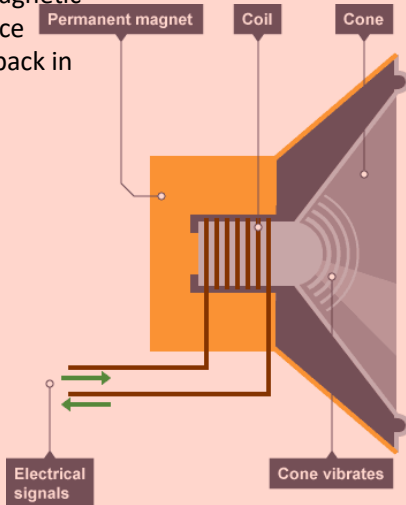

### 9. Microphones

Microphones convert sound waves into electrical signals (opposite to loudspeakers).

The sound wave causes a flexible diaphragm to vibrate → moves a coil in a magnetic field → induces a p.d. → generates a current of the same frequency, size and direction as the sound wave.

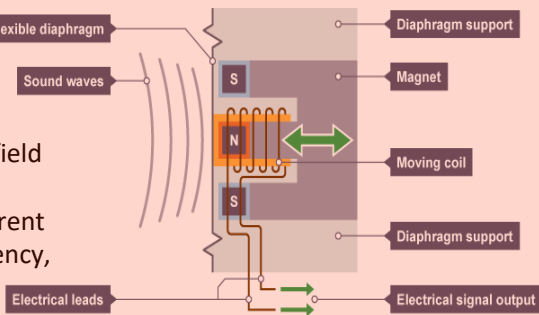

## SINGLE PHYSICS ONLY

### 8. Electromagnetic Induction

Electromagnetic induction is the process of generating electric current with a magnetic field. It occurs whenever a magnetic field and an electric conductor, such as a coil of wire, move relative to one another. The direction of the induced p.d. or induced current depends on the direction of movement. The current is reversed when the magnet is moved out of the coil or the other pole of the magnet is moved into the coil

An induced p.d. or induced current will increase if we:

- ↑ the speed of movement
- ↑ the magnetic field strength
- ↑ the number of turns on the coil

**AC generators** produce a potential difference  
Eg. car alternators - used to keep the battery charged and to run the electrical system while the engine is working.

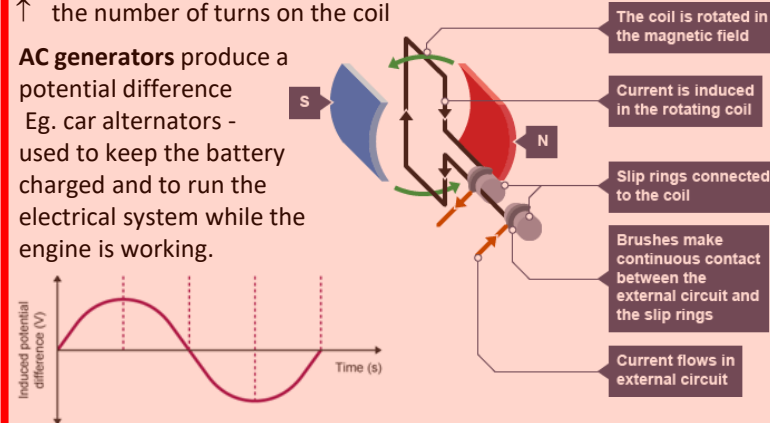

We represent AC generation with an **alternating sine curve**.

**DC generators** produce a potential difference too Eg. a bike dynamo to run the lamps while the wheels are turning.

We represent DC generation with a **sine curve that stays in the same direction** all the time

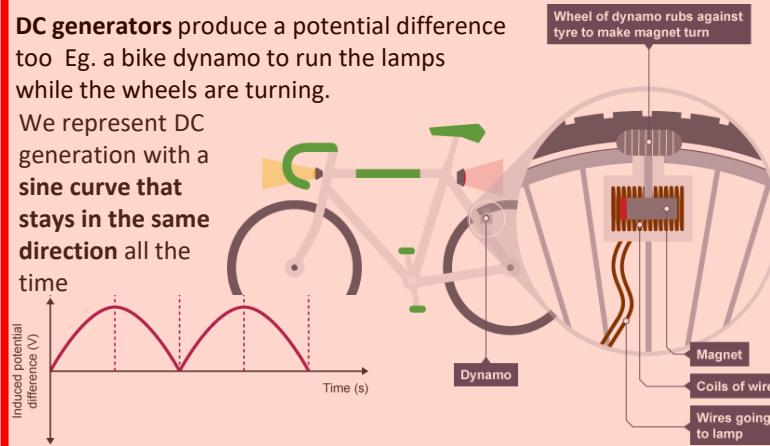

### 10. Transformers

Transformers use electromagnetic induction to change the voltage of alternating currents. The voltage and current changes can be calculated, as the power transfer is **constant**.

$$\frac{V_p}{V_s} = \frac{N_p}{N_s}$$

*Primary voltage (V)* = *number of turns on primary coil*  
*Secondary voltage (V)* = *number of turns on secondary coil*

In a step-up transformer,  $V_s > V_p$   
In a step-down transformer,  $V_s < V_p$ .

$$P = VI$$

$$\text{Power (W)} = \text{Voltage (V)} \times \text{Current (A)}$$

Assuming that a transformer is 100% efficient, the following equation can be used to calculate the power output from the transformer:

$$V_p \times I_p = V_s \times I_s$$

primary coil p.d (V) x primary coil current (A) = secondary coil p.d (V) x secondary coil current (A)

### 11. Power Transmission

The **National Grid** carries electricity around Britain. The higher the current in a cable, the greater the energy transferred to the surroundings by heating. This means that high currents waste more energy than low currents.

To **reduce energy** transfers to the environment, **step-up transformers** are used to **increase** the voltage from power stations (to 400,000V) which lowers the current in the cables. **Step-down transformers** are then used to **decrease** the voltage from the cables, so it is safer to distribute to homes (230V) and factories (10,000V).